



## Design Procedure and Development of a 100KW Solar Power Inverter for off-grid Industrial Use

James Arthur

Department of Accountancy, Godfrey Okoye University, Nigeria

Publication Process	Date
Received	February 7th, 2021
Accepted	February 24th, 2021
Published	February 28th, 2021

### ABSTRACT

A solar power inverter, or converter, also known as PV inverter, converts the variable direct current (DC) output of a photovoltaic (PV) solar panel into a utility frequency alternating current (AC) that can be fed into a commercial electrical grid or used by a local, off-grid electric network. Solar panels generate free power from the sun by converting sunlight to electricity with no moving parts, zero emissions and no maintenance. It is a critical balance of system (BOS)-component in a photovoltaic system, allowing the use of ordinary AC-powered equipment. Solar power inverters have special functions adapted for use with photovoltaic arrays, including maximum power point tracking (MPPT), to get the maximum power from the PV array, and anti-islanding protection. Islanding refers to the condition in which a distributed generator (DG) continues to power a location even though electrical grid power from the electric utility is no longer present. Electrical inverters are devices which convert direct current (DC) to alternating current (AC) such that it matches the voltage, frequency and phase of the power line it connects to. There are numerous technical requirements to the accuracy of this tracking.

**Keywords:** solar, inverter, photovoltaic (PV), maximum power point tracking (MPPT), islanding.

## 1. Introduction

As communities and industries continue to expand, delivering power has become more challenging in developing countries such as Nigeria; the electricity grids have always exceeded their capacities during peak periods while providing electricity off grid becomes more expensive. By utilizing advanced technology, renewable energy sources such as solar power renewable energy source can provide more effective and reliable energy for every level of users. Solar power renewable energy source has become increasingly popular in recent times. Its advantages over non-renewable energy sources, such as coal, oil and nuclear energy are obvious. It is non-polluting, reliable and can produce energy anywhere there is sunlight, thus ensuring a continuous availability of its source. This is because solar power is generated using solar panels, which do not require any major mechanical parts, such as wind turbines and generators or even dam constructed control mechanisms. These mechanical parts can break down and cause maintenance issues and can also be quite noisy. All these issues are virtually non-existent with solar panels. Photovoltaic cells, of which solar panels are made, have been proved to last for couples of decades without need for replacement.

However, there is a drawback to solar power – energy can only be produced when the sun is shining. To overcome this, usually solar panels are coupled with back up rechargeable batteries, which can store excess power generated during the day and use it to provide energy to systems when there is no sun shine. In this way solar power can be used to power houses and other large-scale systems. In these systems DC to AC conversion is needed. This is because the solar panel produces an output that is Direct Current (DC) and the home appliances usually run on AC (Alternating Current), so conversion is required. Using this information, a number of design solutions were determined and considered.

### Overview of Global Energy Demand

Demand for electrical energy has been on the increase in our modern society because of its numerous applications having direct bearing to our day-to-day activities. It is, therefore, an important factor in all the sectors of any country's economy. The standard of living of a given country can be directly related to the per capita energy consumption. In Nigeria, the energy demand far outweighs the supply from the National Grid which is epileptic in nature where energy consumption is projected to grow geometrically but the ability to sustain our growth through energy (hydro, thermal) generation, transmission and distribution continues to dwindle in arithmetic manner. This situation has led to closure of large, medium and small-scale industries and, also, inhibits developmental research activities which resulted in the socio-economic crises Nigeria is witnessing today. The energy crises affecting small and medium scale industries and light household loads can effectively be addressed by devising methods of the energy storage which could be used during the short-period power outage or using a generator which is very costly to maintain. An absolute solution to energy demand can be achieved by adoption of renewable energy development especially the abundant solar energy system.

According to the National Renewable Energy Laboratory, the solar energy that reaches the earth in one hour is about as much as the total energy used by everyone on the planet for an entire year. Although harnessing solar energy is far from being considered efficient by today's means, it is still a low cost, sustainable, safe, and environmentally friendly when compared to other means of generating electricity such as coal or nuclear power plants. The solar industry is the fastest growing segment in the alternative energy sector. It was projected to grow from \$11B in 2005 to \$51B in 2015 (Sridhar). There are two types of what is referred to as solar energy to electricity conversion: concentrated solar power (CSP) and photovoltaic (PV). CSP are large installations where direct sunlight is concentrated by numerous large mirrors and is used to generate steam to drive a turbine by a Rankin or Bray to cycle that generates electricity (El-Wakil). Those systems typically power communities, as their size is not appropriate for an individual household. The other type, PV, uses diffused and direct sunlight to generate electricity, and can be more compact, such as solar powered calculators. This report will focus on PV systems.

The increasing demand for energy via greener methods and the gradual depletion of fossil fuels, solar energy conversion has regained the spotlight of the global energy activities. Our planet receives 160,000TW of solar energy, while the present global energy demand is about 16TW. While the solar resource is virtually unlimited, conversion of solar energy to readily usable form is too expensive to be commercially successful at present. Furthermore, reliable solar technology has to be complemented by energy storage system to accommodate the daily and seasonal variations in the solar radiation. From this perspective, many countries have formulated their long-term solar energy utilization roadmap.

## 2. Literature Review

### Review of Related Works

Several milestones have been recorded in the area of the development of solar power inverters as technology continued to evolve and advance over the years. This chapter treats a number of such works and achievements to a reasonable extent.

In **“How Solar Works,”** by **California Energy Commission & California Public Utilities, 2016**, an insight was given. According to this work, sunlight can be directly converted to electricity using solar cells. Every day, light hits our roof’s solar panels with photons (particles of sunlight). The solar panels convert those photons into electrons of direct current (DC) electricity. The electrons flow out of the solar panel into an inverter and other electrical safety devices. The inverter converts the resulting DC power (commonly used in batteries) into alternating current or AC power. The AC power is the kind of electrical current used by household and office equipment such as television sets, toasters and computers. Solar cells are made up of photovoltaic (PV) components. However, since photovoltaic (PV) system needs unobstructed access to the sun’s rays for most or all of the day to be effective, shading the PV system should be avoided. Shading on the system can significantly reduce the energy output. This condition is a notable shortcoming on the system of solar energy inverters as absence of sunlight reduces efficiency drastically. To obviate this condition, the following other solar technologies have been developed: concentrating Solar Power (CSP) systems where the sun’s energy is of highest intensity by using reflective devices such as troughs or mirrors to produce heat that is then used to generate electricity; using solar water heating systems which contain a solar collector that faces the sun and either heats water directly or heats a “working fluid” that in turn is used to heat water and applying transpired solar collectors, or “solar walls” using solar energy to preheat ventilation air for a building. All these are aimed at obviating the shortcomings experienced in situations where there are shading on the solar panels.

According to **Colins Schauder, (2014)**, in, **Advanced Inverter Technology for High Performance Penetration Levels of PV Generation in Distributed Systems**, inverters are electronic power converters that can be used to couple DC or variable-frequency power sources to the grid. Practically, as he opined, all renewable power generation systems depend on inverters for their grid connections. This underscores the relevance of inverters in all practical aspects of power or energy generation. In these applications, the primary function of the inverter is to deliver the maximum possible generated real power as efficiently as possible to the grid. First generation PV inverters, according to him, were typically designed with only the basic controls necessary to perform this primary function. This is because grid connection is intended. For low power levels (less than 500kW) and low levels of PV power generation, certification of the equipment to these standards was sufficient for utilities board to allow interconnection to the grid without much concern.

However, in addition to frequency conversion and basic real power delivery, inverters also have a number of inherent control capabilities that are widely used elsewhere, other than power conversion, in power systems for power management and power quality improvement. The researcher concludes by saying that when connected to an established power grid (i.e. where the frequency and voltage are actively regulated), inverters typically operate as controlled device so that the output current from the inverter is active and follows a reference signal. With optimum design, the output current control can be extremely fast (less than 1ms response) and accurate (less than 1%). Also, the control response can be practically unaffected by disturbances in the grid voltage. The foregoing treats the relevance of inverters as an interconnection between generated power from renewable energy source and existing grid.

In a work titled, **“How grid-connected PV Systems Work,”** carried out by **Ashden Sustainable Energy Company, USA, 2016**, a further insight was given as presented below.

Photovoltaic, PV, modules use semiconductor materials to generate direct current, DC, directly from sunlight. A large area is needed to collect as much sunlight as possible, so the semiconductor is either made into thin, flat, crystalline cells or deposited as a very thin continuous layer unto a support material. The cells are wired together and sealed into waterproof module, with electrical connectors added. Modern modules for grid connection usually have between 48 and 72 cells and produce DC voltages of typically 25 to 40 volts, with a rated output of between 150 and 250 Watts.

In order to supply electricity into the mains electricity system, the DC output from the module must be converted to AC at the correct and exact voltage and frequency. An electronic inverter is used to do this. Generally, a number of PV modules are connected in series to provide a higher value of DC voltage to the inverter input, and sometimes several of these 'series strings' are connected in parallel, so that a single inverter can be used for 50 or more modules.

Modern inverters are very efficient, up to 97%, and use electronic control systems to ensure that the PV array keeps working at its optimum voltage rating. They are also made to adhere to design conventions in their country of use.

Following the above procedure, the desired inverter was successfully designed and implemented and the resulting output was suitable for use by conventional electrical appliances. However, precautionary measures taken were to ensure that the battery DC voltage was constant. This achieved by ensuring that no shading of the panels is allowed.

### 3. Methodology and Data Analyses

#### Design Methodology

The solar power supply system is designed to provide constant power to electronic appliances connected to it in absence of sun. It continuously powers the protected load from its energy reserves stored in a lead acid battery, while simultaneously replenishing the reserves from the dc voltage coming from the solar panel. It also provides protection against all common power problems. The dc lead acid battery is continuously recharged as it discharges so that in event of sun set, the reserve energy left the battery can be used to power electronic equipment connected to it.

#### Specification

This choice of choosing the type and rating of components needed is termed specification and involves referring to an already existing one which has the same pattern of design.

##### i. Solar panel

The choice of solar panel is made from commonly seen and available 130watts 12volts Polycrystalline silicon photovoltaic cell, to convert the solar energy into electrical energy (Direct Current).

##### ii. Charge controller

From the requirement of the supplied component voltage, a choice of a 36vdc 60Amps charge controller that will regulate the amount of current flowing from the solar panel to the system and also ensures that the batteries are not over charged was made.

##### iii. Battery

The durability and efficiency of the system lies on the battery, as it provides energy storage for the system. Hence a choice of 100Amps 12vdc deep cycle battery was made. It charges quickly and takes longer time to discharge compared to other types of batteries, such as car batteries.

##### iv. Inverter system

The inverter converts the dc voltage coming from the solar panel to ac voltage. Since the rating of the inverter is of optimum concern in the solar power supply system, it was decided to construct a 2400watts pure sine wave inverter system

### The Block Diagram of Solar Power Supply System

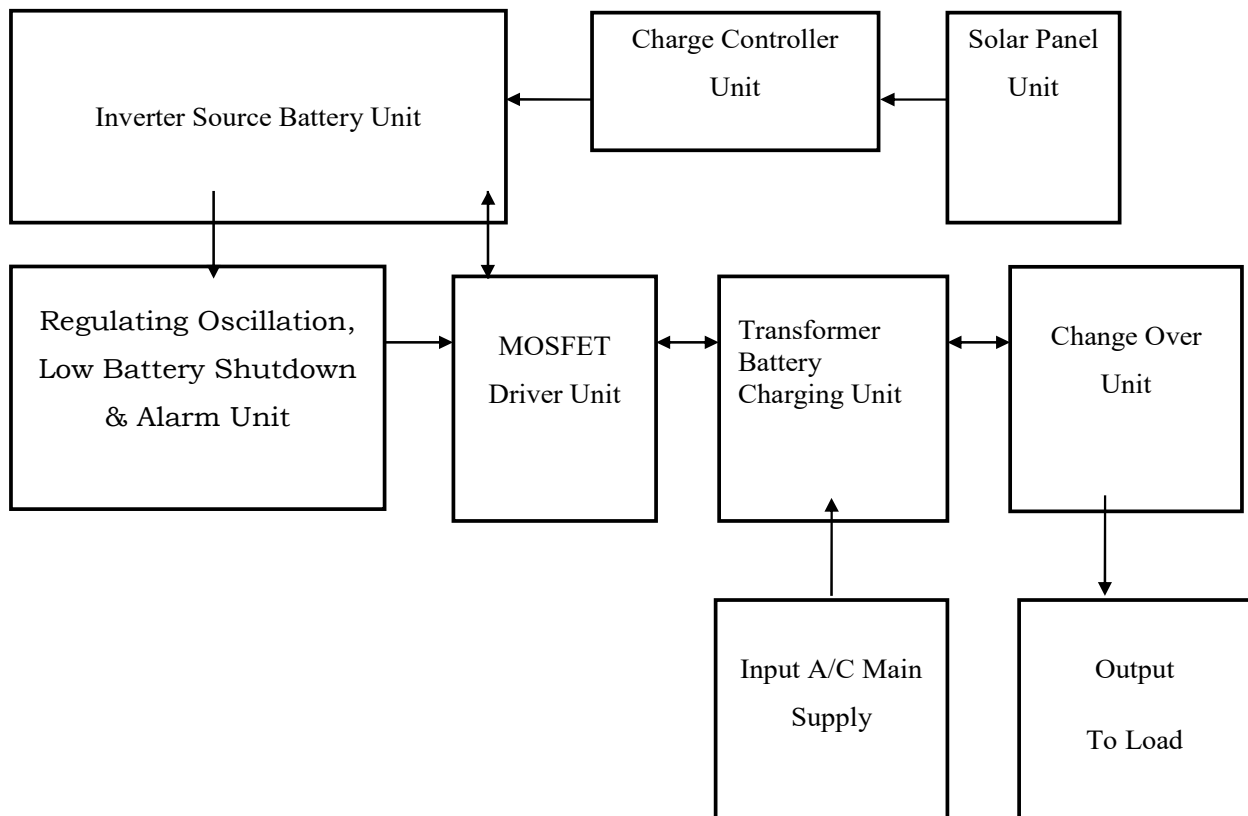

**Figure 3.1: Solar power supply system block diagram**

#### The System Operation with Block Diagram

The solar panel absorbs energy produced by the sun and converts it into electrical energy. It does this by absorbing the sun rays into the modules of the solar panel hence produced free electrical charge carriers in the conduction and valence bonds. The electricity produced by the solar panel was then transferred to the charge controller as shown in fig 3.1 above. The charge controller regulates the rate at which electric current is drawn in and out of the battery. It turns off charge when the battery reaches the optimum charging point and turns it on when it goes below a certain level. It fully charges the battery without allowing overcharge.

The regulated voltage from the charge controller was then transferred to the solar battery. The batteries were the key component in this solar power system. It provided energy storage for the system.

The energy stored in the batteries was used to power the load but it was first converted to AC voltage by the use of an inverter since they are AC loads. The photovoltaic alloy produced direct current was transformed periodically by controlled oscillatory system and fed to power electronic semiconductor switches such as MOSFET which were connected to the power transformer. Here the voltage was stepped up to the desired ac voltage. The inverter could also charge the battery when there is public power supply.

The Circuit Diagram of Solar Power Supply System

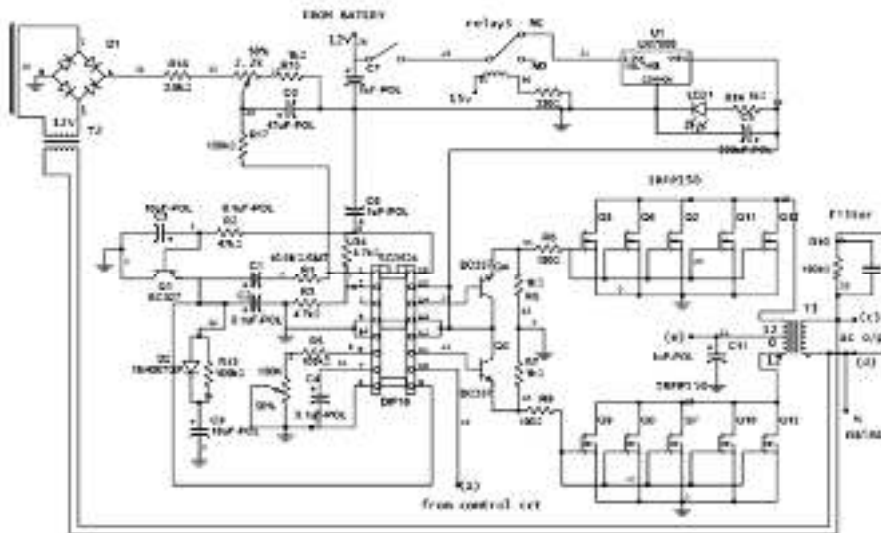

Figure 3.2 Solar power supply System circuit diagram

Figure 3.2 showed the circuit diagram of solar power supply. This is made use of in the implementation of this research.

The Inverter Oscillator Circuit Diagram

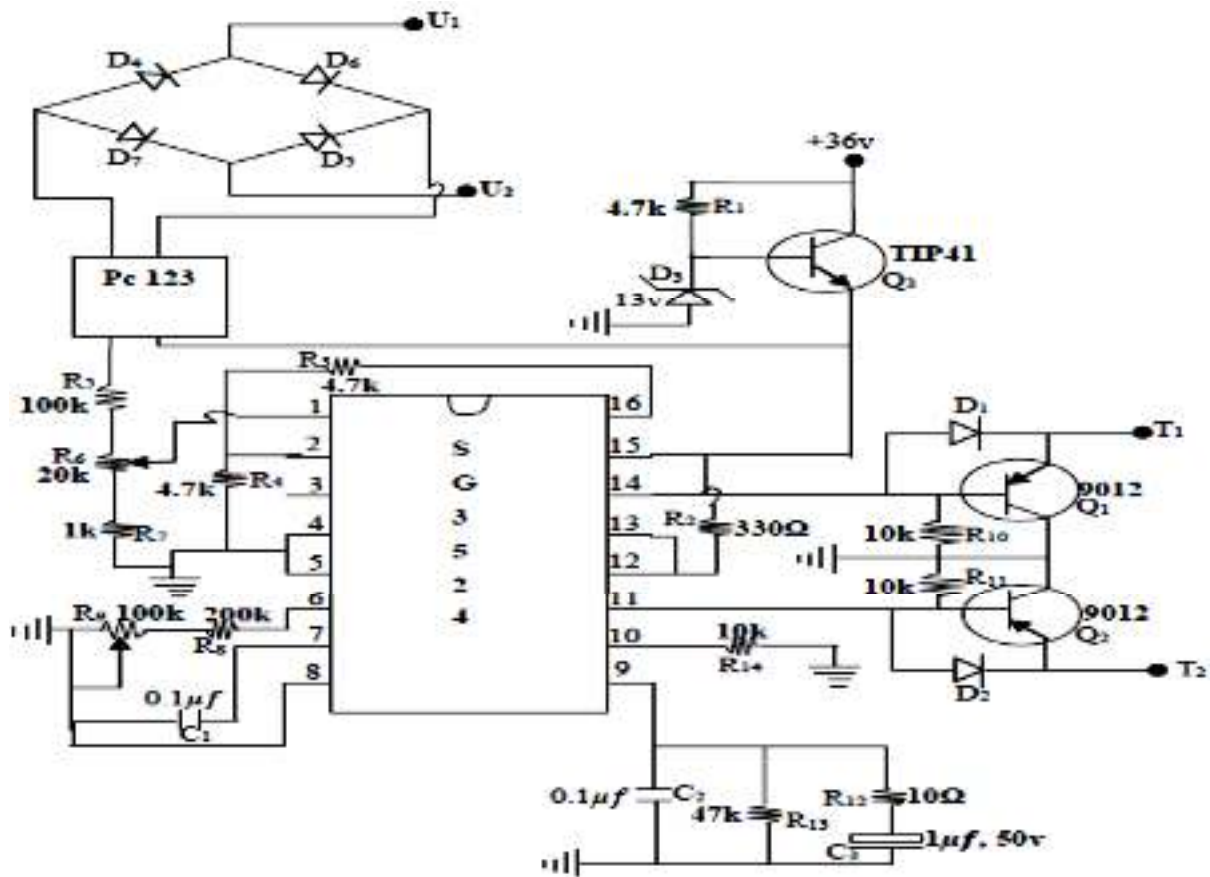

Figure 3.3 PWM inverter oscillator circuit diagram

In Figure 3.3, the circuit diagram of a PWM inverter oscillator is shown. An oscillator is an electronic circuit that has the ability to change a direct current (D.C) into an alternating current (A.C) without any external input. An oscillator comprises of ICs and filtering components like capacitor and resistor. Unlike an amplifier that requires an external input e.g. voice, an oscillator on the other hand does not require external input.

In this design, the oscillator intended for use is an S-G 3524 IC. When it is powered by a 12v VCC Direct current (D.C) the oscillator produces an alternating current at its dual output which is now fed to the buffer. The buffer stage consists of the transistors. The buffer amplifies that output signal from the oscillator. It operates like the oscillator but it is one amplifier connected in a complementary push-pull method. It is a class B-amplifier.

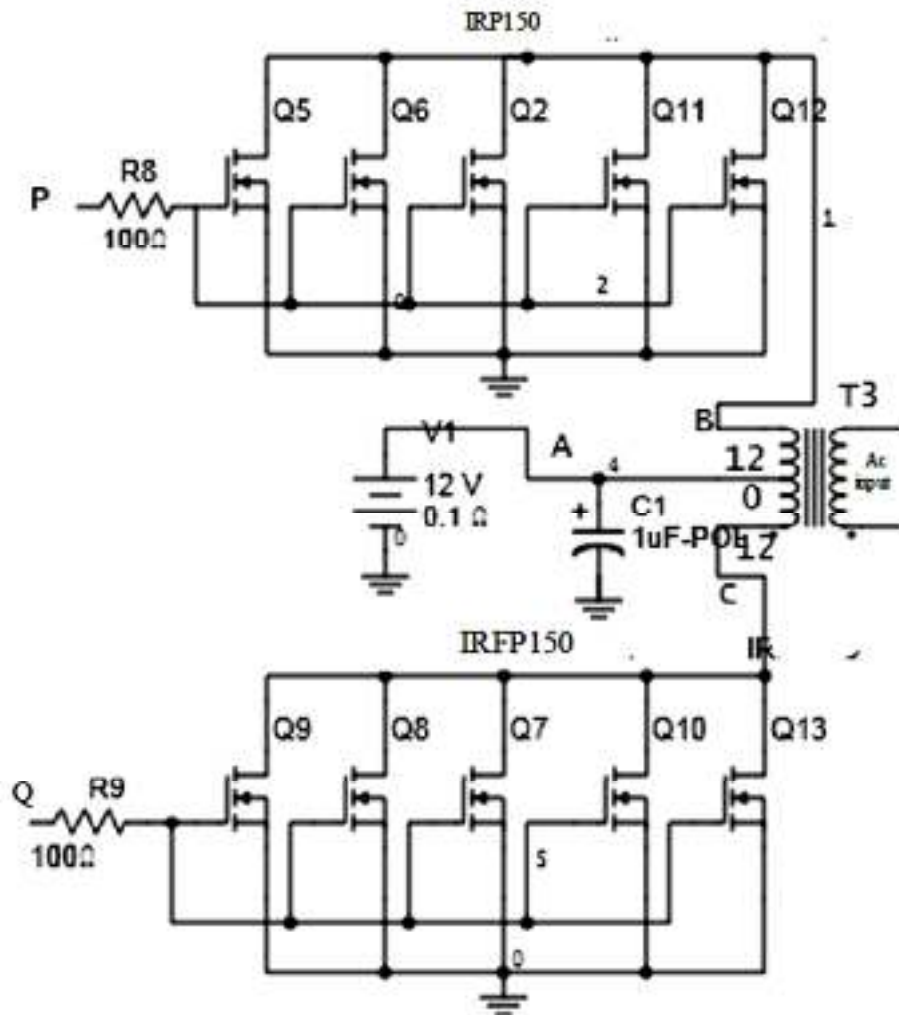

Figure 3.4 Designed MOSFET circuit in the reverse direction

In this construction work, the buffer stage consists of four N-channels IRF 3205 MOSFET transistor. They are arranged in parallel, five being connected in series and coupled to one input terminal of the transformer; the other five are also connected in parallel and coupled to the other input terminal of the transformer.

### System Implementation and Packaging

#### Actual Design Processes

First, a block diagram of the design which describes in details the functions of each unit of the design that leads to the selection of the type of components required to perform the operation very well without breakdown at any

point in time. This is followed by the circuit diagram of the design using a especial software which helped in giving clear specifications of the components selected, then the diagram is drawn in accordance with the working principles and how each components was interconnected to each other to form the circuit.

### Prototype Construction

A typical prototype technique is the bread board construction or layout. It is a temporarily carried out layout to test the working of the circuit designed. The bread board is a plastic plate with holes running both vertically and horizontally.

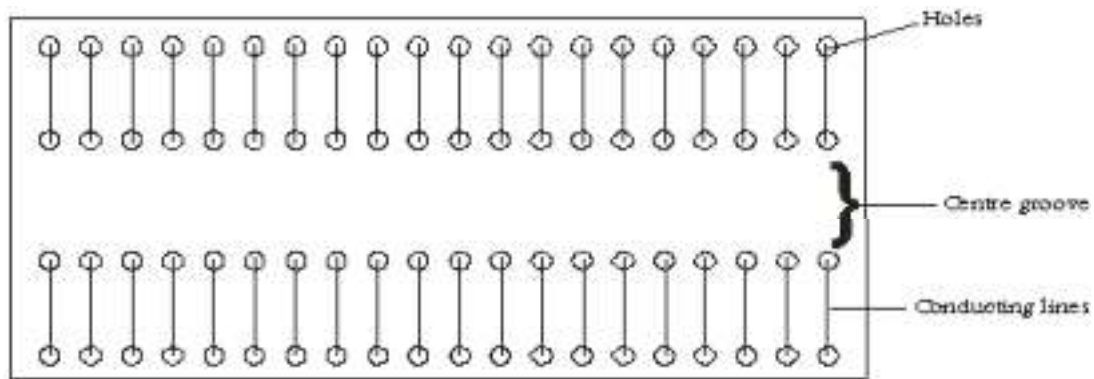

Fig 5.2 Breadboard

Figure 4.1 Bread/Project board

The holes are embedded with copper tracks to form conduction lines into which the components are plugged into. Initially, the components were counted with the aid of the circuit diagram, all the component assuming a convenient position on the bread board. The IC is fitted the correct way with both conducting leads across the center groove. Other circuit elements like the switches, output socket, DC battery and voltmeter are connected outside the breadboard with the help of jumping wires; hence they cannot be plugged in the bread board. The bread board construction is usually essential because modification of the circuit can be easily achieved. The component can be used several times over to make different circuits.

### Actual Constructions

The strip board is used for the permanent construction. The strip board is a matrix board which consists of parallel stripes of copper known as tracks fixed on to an insulating board. All the tracks are of equal width and space apart. It is used to achieve permanent fittings of components as they are carefully soldered to make permanent joints.

To achieve the final finished product of this design, the strip board layout was carried out. The different sizes of components were taken into consideration during the circuit layout on the graph sheet. For easy connection, the boards were numbered alphabetically like A, B, C, and D and so on. It reduces the chances of making mistakes.

**Note:** All markings were done on the non-copper side of the strip board



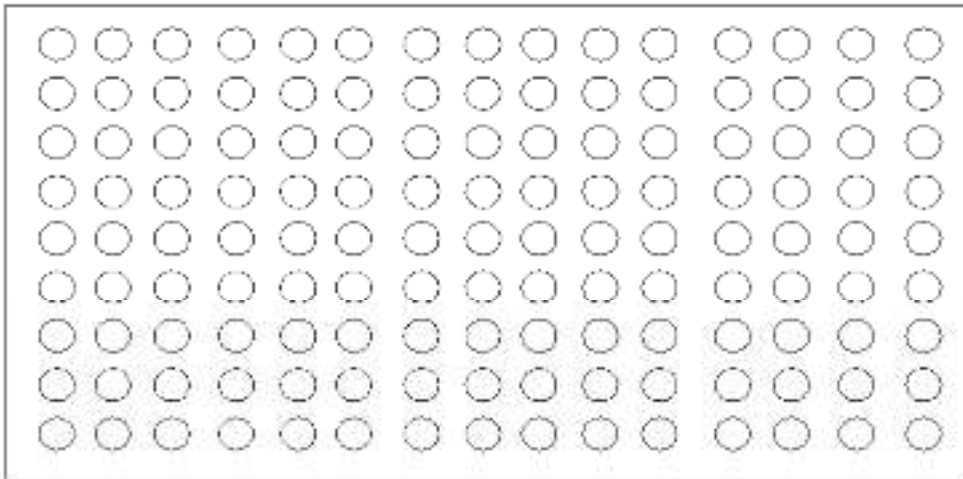

**Figure 4.2 A strip board**

The order of placing components is not essential, although more delicate components such as IC and transistors are mounted with great care. Though some people prefer starting from one end of the strip board and work across, all soldering are on the copper side. Before using the strip board, it is first cleaned with smooth abrasive paper (sand paper) to ensure dry surface which in turn will produce a neater solder contact. The power rating of soldering iron used is 20 watts. The heat produced being enough to achieve good soldered joint.

Dry joints are carefully avoided as it may lead to partial contacts or open circuit in the system. However, dry joints have been attributed to so many failures recorded in a project work. After soldering, the leads are carefully cut with slide cutter to ensure neat work.

Later the strip board is checked of bridged tracks and mistakes from the construction, positive feedback avoided as the output wires made neat contact and are not too close to the input leads.

### **Packaging**

Packaging determines how well a developed product is appreciated and sold to the public. To this end, a well thought out packaging not only uplifts the image of a design but also have attractive luster attached to it. People attach great importance to the shape and design of the casing without considering the contents.

In this design, the casing was built in such a way that the components are easily accessible in terms of maintenance and repairs. The casing has screwable cover and the provision for components or circuit fittings are made. The tracks and wires on the strip board do not touch the metal case. In preparing the casing, a plain sheet of metal is obtained and a given dimension measured out with the measuring tape. The dimensions are marked out with a scribe and then cut with a cutting machine to the dimensions marked on the metal. The whole centers were punched with the center punch and drilled into appropriate size with the drilling machine.

After this, the metal was bent with the help of a vice, hammer and some other small accessories. Finally, screw nails were used to screw the necessary junctions together to place the casing intact.

### **Trouble Shooting**

Trouble shooting involves diagnosis (fault tracing), location and reticulation of faults. Skill in diagnosis allows identification of faults which arises in a system, so that their cause may be found quickly and accurately.

To develop this skill, a logical approach to fault tracing is employed. First there is need to verify the fault by operating the system. After which careful inspection on the system is made, adopting both cold and hot inspection if cold inspection fails to yield result. Later the system is sectionalized into different stages and then the fault is traced at each stage.

In this project, when the power was first switched on, the indicator failed to light up. This leads into diagnosing the fault and subsequently rectifying it. The fault was traced to open circuit on the indicator lead due to poor soldering. Instruments necessary for trouble shooting includes: oscilloscope, analogue and digital multi-meter.

### **Materials Required for Installation**

A metal frame which is 32cm x 94cm is required and will be attached to the roof so that the solar panel will be mounted on this frame and will be held securely. An extra 2mm<sup>2</sup> of wiring is required to reach the batteries. A ladder is required to complete the installation of the frame and solar panel. This is to be completed by the school's maintenance officer.

### **Test and Results**

The solar panel was set placed under the sun at 45° south, there the peak sun irradiation was on the panel surface and then at 39.5 volts was observed using a multi-meter. While observing the voltage, the panel was slightly adjusted and the voltage varied at an angle away from the sun, the voltage depreciated.

The output from the solar panel was connected to the charge controller with respect to their polarities and when the output voltage was observed, it then read 26 volts which was right for charging 24 volts battery, since the two 12 volts batteries were connected in series. Also, there was an indicator on the charge controller that showed when the battery was full by showing green light and the other LED showed red when load was connected to the system.

Each battery read 12.8 volts each and then connected in series to give an output of 24 volts afterwards was connected to the inverter. The voltage was 25.7 volts DC because the solar and the charge controller were also connected but without load, then load was added to the inverter which gave an output of 220 volts and was left for about 30 minutes after then it was observed again and the voltage did not vary. The inverter had three indicators. The first displayed if the system was connected to the mains or not, the second displayed if the inverter system was switched ON or OFF and the third was to display if the system was experiencing any fault or not.

The inverter also had an additional socket for plugging the inverter to mains to serves as another means to charge the batteries other than the solar system. When tested with the volt meter as it was plugged on the mains out, it read 14.4 volts which was basically because of the state of the charge level of the batteries. The batteries would normally self-discharge over time even when not used. Since the inverter included a triple cycle charger, it could continue to maintain the battery with equalization charge voltage of about 12 volts just to make sure that the battery does not discharge even it was on standby mode.

### **Conclusion**

The solar power system has immense advantage in every area where power is required. It is a fact that there is hardly any aspect of human life where electrical power is not required, at homes, offices, hospitals, etc.

The project was intended to supply 100kilo watts of energy to the office and homes and ultimately to serve as alternative source of electricity.

The solar system works effectively and costs no further operational cost once designed and developed. When compared to a 100 kilo watts diesel generator, it is costly but for the initial expenses. However, it is later seen to be cheap since the system needed no petrol to operate but sunlight which is nature's free gift. Therefore, there is no need to time or limit the hour of power supply of the up and down experiences from the mains supply.

The solar power system is a convenient way of producing an alternative means of power supply to supplement the mains failure. It is advantageous to user who could afford its initial cost of installation.

## References

- A. S. Samosir, A. Trisanto and A. Sadnowo (2017): Development of Dynamic Evolution Control for PV Inverter in Solar Power Plant Application; ARPN Journal of Engineering and Applied Sciences, VOL. 12, NO. 12, 2017
- Albert Alexander Stonier (2017): Design and Development of High Performance Solar Photovoltaic Inverter with Advanced Modulation Techniques to Improve Power Quality; International Journal of Electronics Volume 104, 2017 - Issue 2.
- Ashden Sustainable Energy Company, USA, 2016: How grid-connected PV Systems Work.
- California Energy Commission & California Public Utilities, 2016: How Solar Works.
- Chang Hee Han, Bo Kyung Ko, Sung Yoon Song and Gilsoo Jang (2017); Application of PV Inverter on Distribution System with High Penetration of PV; Journal of International Council on Electrical Engineering, Volume 7, 2017 – Issue 1.
- Edison E. Mojica, Jorge Z. Burgos, John Alfred C. David, Allan T. Diaz II, Danylle I. Diaz, and Rowell G. Gatbunton (2015): Design and Development of the Power Generating System of a Solar Powered Cell Phone Charging Station; International Journal of Electrical and Electronics Research, Vol. 3, Issue 4, pp: (180-200), 2015.
- Gaurav Arora, Neha Aggarwal, Debojyoti Sen, Prajjwal Singh (2015): Design of Solar Power Inverter; International Advanced Research Journal in Science, Engineering and Technology (IARJSET), National Conference on Renewable Energy and Environment (NCREE-2015) IMS Engineering College, Ghaziabad Vol. 2, Special Issue 1, May 2015.
- Md.Nahid Hossain, Tushar Kanti Routh, Abdul Hami Bin Yousuf Miah, Md. Asasduzzaman, Md. Iqbal Hossain and Ummul Husnaeen (2012): Design and development of a grid tied solar inverter IEEE/OSA/IAPR International Conference on Informatics, Electronics & Vision.
- Temitayo O. Olowu, Aditaya Sundararajan, Mashood Moghaddami and Arif I. Sarwat (2018): Future Challenges and Mitigation Methods for High Photovoltaic Penetration: A Survey: Energies2018, 2018, 1782.